

# A contribution to the properties of combined plywood materials

J. HRÁZSKÝ, P. KRÁL

*Faculty of Forestry and Wood Technology, Mendel University of Agriculture and Forestry Brno, Brno, Czech Republic*

**ABSTRACT:** The paper summarizes the results of institutional research aimed at new types of combined plywood materials. Under pilot plant conditions, three variants of combined plywood materials were pressed, namely with the layer of fibreglass, with a core cork layer and with a cork wear layer on one side of the plywood surface and a cork core. Tests of selected physical and mechanical properties were carried out on these materials including the basic statistical evaluation. Comparisons with plywood materials Multiplex 15 and 20 mm in thickness were also made.

**Keywords:** combined plywood; density; moisture; bending strength; modulus of elasticity in bending; statistical analysis; cork core; fibreglass surface

Plywood is often named as the first from the group of products which are known as engineered wood at present. It was the first material that consisted of disintegrated wood particles in order to create larger and solid composite units, firmer and tougher than the sum of the values of their parts (HRÁZSKÝ, KRÁL 2005). At the end of the 70s and at the beginning of the 80s of the 20<sup>th</sup> century, the principle of plywood allowed the origin of OSB (oriented structural boards). Other products from the group of engineered wood are: Parallam PSL, Intrallam LSL, Microllam LVL and TJI beams. These products combine properties of wood, also making it possible to use valuable natural resources more economically (BAO et al. 1996; SHARP, SUDDARTH 1991).

In addition to their static function combined plywood materials show various special functions, e.g. thermal and insulating ones. Through the combination of these two requirements a material originates which is more advantageous compared to the use of separate materials (KRÁL, HRÁZSKÝ 2006). This advantage consists not only in the price area but also in the simplicity of production technologies and production productivity. Combined plywood materials are not manufactured in such a volume as

plywood for construction purposes and e.g. for the manufacture of formwork (HRÁZSKÝ, KRÁL 2004). Specialized companies produce these plywood materials in smaller custom-made volumes. In the production range of these companies, sandwich elements occur completely without wood components (e.g. combined boards for the manufacture of doors into passive houses, ice boxes) or these firms offer these materials as “specialities”. Nevertheless, the manufacture of these materials is much more exacting from technological aspects and also more expensive. Therefore, their market has to be ensured in advance. A Finnish manufacturer of plywoods, Koskisen Company, which is the supplier of combined plywood materials for the manufacture of lorries, can serve as an example. This firm has a development team (PDT – Plywood Development Team) who is in charge of cooperation with consumers at the development of new combined materials.

## MATERIAL AND METHODS

The aim of the study was to determine properties of newly developed plywood materials combined with cork and fibreglass and their comparison with

---

Supported by the Ministry of Education, Youth and Sports of the Czech Republic, Project No. MSM 6515648902.

standard plywoods – multiplexes, and comparison with properties of similar materials produced by reputable companies (KRÁL, HRÁZSKÝ 2003).

Flexural load occurs in a number of technical applications of plywoods. The exact knowledge of required values of flexural load for the particular types of use makes it possible to design plywoods of optimum construction. Physical (density, moisture) and mechanical (bending strength, modulus of elasticity in bending, glue-bond strength, shear strength in Variant 2) properties were determined. The obtained values were processed by description statistics. The selection of samples, determination of bending strength and modulus of elasticity at the bending of plywoods as well as related properties were carried out according to the following ČSN EN standards:

- ČSN EN 326 – 1 Boards of wood. Sampling, cutting and inspection. Part 1: Sampling, cutting specimens and the formulation of test results
- ČSN EN 325 Determination of specimen dimensions
- ČSN EN 310 Determination of the modulus of elasticity in bending and bending strength
- ČSN EN 322 Determination of moisture
- ČSN EN 323 Determination of density
- ČSN EN 314 – 2 Requirements for the quality of gluing plywoods.

From each of the plywoods, 12 test specimens were cut to determine bending strength (6 specimens in longitudinal direction, 6 in cross direction), 6 to determine density, 6 to determine moisture and in Variant 2, 6 specimens to determine shear strength (glue-bond strength). In the paper it is calculated with one-dimensional bending of orthotropic material.

Bending strength and modulus of elasticity in bending were determined using a test machine ZWICK, model Allround, measuring range 10-20-30-50-100 kN.

#### Material – variants and the structure of plywoods

##### *Variant 1 – plywood with fibreglass (11-ply, thickness 16 mm)*

Structure:

- phenolic foil,
- 11-ply plywood (11 × beech veneer 1.5 mm thick),
- non-woven fibreglass,
- phenolic foil.

A layer of fibreglass was laid on previously pressed 11-ply plywood. The plywood was then two-side coated using a phenolic foil. The unit was pressed using the following pressing parameters:

- gluing AW 100 (PF adhesive),
- working pressure 1.5 MPa,
- working temperature 125°C.

##### *Variant 2 – plywood with a cork core (11-ply, thickness 22 mm)*

Structure:

- 5-ply plywood (beech 1.5; spruce 2.5; beech 2.5; spruce 2.5; beech 1.5 mm),
- cork core, thickness 3 mm,
- 5-ply plywood (beech 1.5; spruce 2.5; beech 2.5; spruce 2.5; beech 1.5 mm).

For the manufacture, previously pressed plywoods 10 mm thick were used and a cork layer was inserted between them. The unit was pressed using the following pressing parameters:

- gluing IF 20 (UF adhesive),
- working pressure 0.4 MPa,
- working temperature 110–120°C.



Fig. 1. Variant 1 – plywood with fibreglass (11-ply, thickness 16 mm)

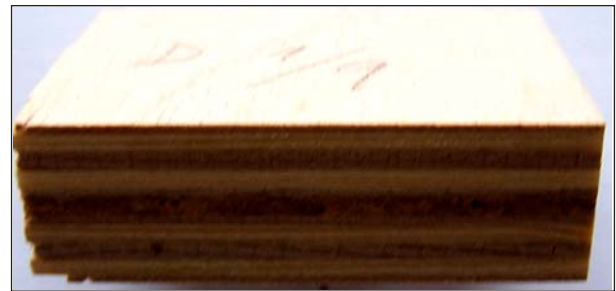

Fig. 2. Plywood with a cork core (11-ply, thickness 22 mm)



Fig. 3. Plywood with a cork core and a cork wear layer (12-ply, thickness 25 mm)

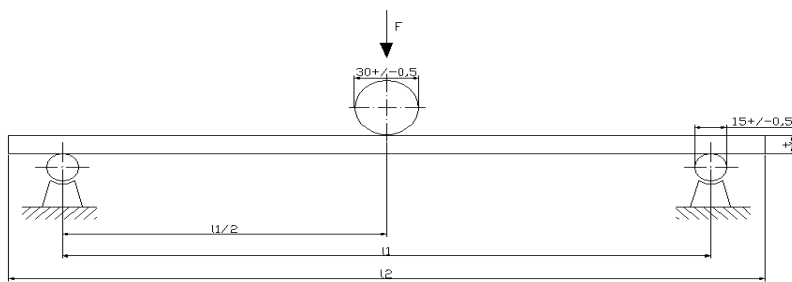

Fig. 4. The principle of measuring the modulus of elasticity and bending strength

**Variant 3 – plywood with a cork core and a cork wear layer (12-ply, thickness 25 mm)**

Structure:

- cover (top) cork layer, thickness 3 mm,
- 5-ply plywood (beech 1.5; spruce 2.5; beech 2.5; spruce 2.5; beech 1.5 mm),
- cork core, thickness 3 mm,
- 5-ply plywood (beech 1.5; spruce 2.5; beech 2.5; spruce 2.5; beech 1.5 mm).

For the manufacture, previously pressed plywoods 10 mm thick were used and a cork interlayer was inserted between them. Another cork layer was laid on one upper side. The unit was pressed using the following pressing parameters:

- gluing IF 20 (UF adhesive),
- working pressure 0.4 MPa,
- working temperature 110–120°C.

All materials were pressed using a laboratory press 700 × 700 mm in size, sampling was carried out according to the ČSN EN 326 –1 standard.

**Determination of modulus of elasticity and bending strength according to ČSN EN 310**

The method consists in the loading of a sample that is suspended on two supports whereas the single loading interacts in the middle of sample (Figs. 4 and 5).

During the test the width and thickness of the sample, and the distance of supports are measured, and deflection at loading and maximal faulted loading are determined.

Modulus of elasticity is calculated from the linear section of the loading-deflection curve and from the distance of supports, width and thickness of the sample. The calculated value is apparent, not the real modulus of elasticity, because the testing method covers also shear besides bending. Bending strength of each sample is calculated as the quotient of bending moment  $M$  at maximal loading of the sample  $F_{max}$  to the moment of its integral profile.

The loading force acts with constant feed speed in the process of testing. The loading speed is such that maximal loading will be attained at  $(60 \pm 30)$  s.

Deflection in the middle of the sample (under the loading head) is measured to the nearest 0.1 mm. This value is plotted in a diagram with corresponding loading measured with 1% exactness.

The materials in variant 1–3 were not evaluated in this part of research project from the aspect of separate layers, consequently the modulus of elasticity and bending strength of separate layers were not analyzed.

**Formulation of test results**

Modulus of elasticity  $E_m$ :

$$E_m = \frac{l_1^3 (F_2 - F_1)}{4bt^3 (a_2 - a_1)}$$

- where:  $l_1$  – distance between the centres of supports (mm),  
 $b$  – width of sample (mm),  
 $t$  – thickness of sample (mm),  
 $F_2 - F_1$  – load increment in the straight line of loading diagram (N);  $F_1$  has to be approximately 10%,  $F_2$  40% of maximal loading,  
 $a_2 - a_1$  – increase in the deflection of the sample at the point of load force (mm), adequate to loading increment  $(F_2 - F_1)$ .

The modulus of elasticity of each sample has to be defined with effect for three significant decimal positions.

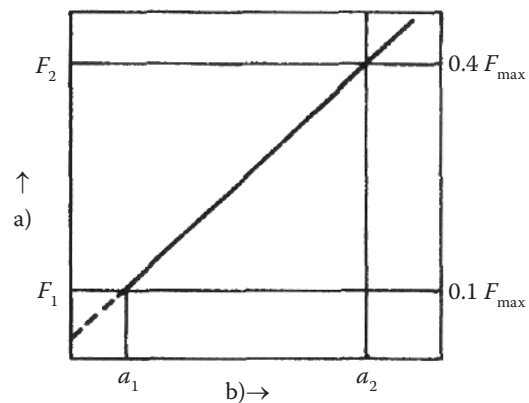

Fig. 5. Loading diagram for the determination of modulus of elasticity

Table 1. Bending strength  $f_m$  and modulus of elasticity  $E_m$  along the grain (N/mm<sup>2</sup>) – ČSN EN 310

Property	Variant 1		Variant 2		Variant 3	
	$f_m$	$E_m$	$f_m$	$E_m$	$f_m$	$E_m$
$m$	112.34	1,1406.5	46.07	5,191.25	41.15	2,142.58
$s$	10.68	560.11	3.92	269.26	2.40	230.46
$L_{5\%}$	92.15	1,0347.89	38.66	4,682.34	36.61	1,707.01
$V$ (%)	9.51	4.91	8.51	5.19	5.84	10.76

Bending strength  $f_m$ :

$$f_m = \frac{3F_{\max}l_1}{2bt^2}$$

where:  $F_{\max}$  – loading of sample at failure (N),  
 $l_1$  – distance between the centres of supports (mm),  
 $b$  – width of sample (mm),  
 $t$  – thickness of sample (mm).

The bending strength of each sample has to be defined with effect for three significant decimal positions.

### RESULTS

Five boards were pressed from each of the variants of combined plywoods (1–3). Selected physical and

Table 2. Bending strength  $f_m$  and modulus of elasticity  $E_m$  along the grain (N/mm<sup>2</sup>) – ČSN EN 310

Property	Multiplex 20 mm thick		Multiplex 15 mm thick	
	$f_m$	$E_m$	$f_m$	$E_m$
$m$	88.63	9,464.5	102.68	10,636.88
$s$	9.90	411.05	6.27	781.21
$L_{5\%}$	69.92	8,687.62	90.82	9,160.38
$V$ (%)	0.34	4.34	6.11	7.34

mechanical properties were determined according to ČSN EN standards. Because it was not the routine series production, the particular boards of variants 1–3 were not evaluated separately and compared with one another, but within each of the variants all plywoods (1–5) were evaluated as one set ( $n = 30$ ).

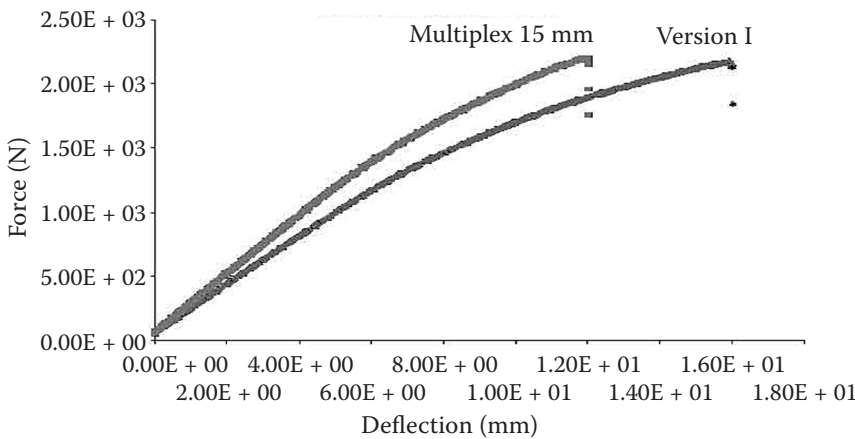

Fig. 6. Comparison of the course of force and deflection – bending strength across the grain – Variant 1

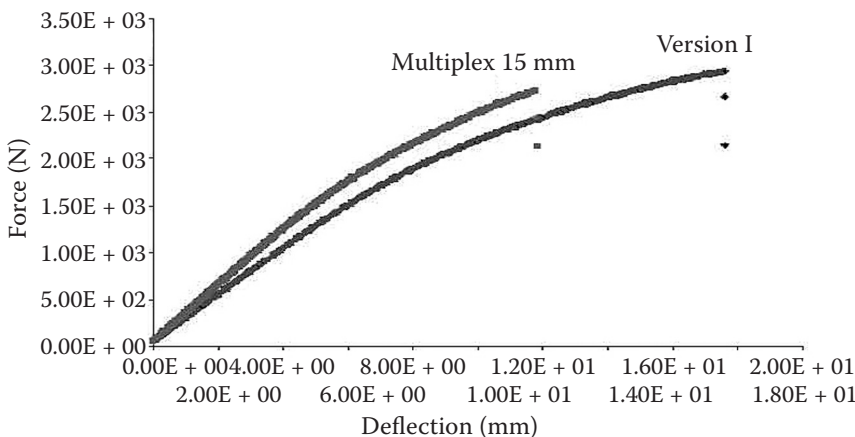

Fig. 7. Comparison of the course of force and deflection – bending strength along the grain – Variant 1

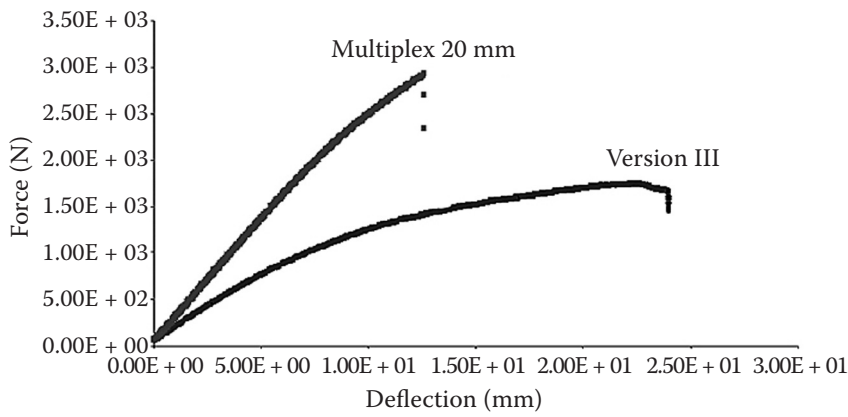

Fig. 8. Comparison of the course of force and deflection – bending strength along the grain – Variant 3

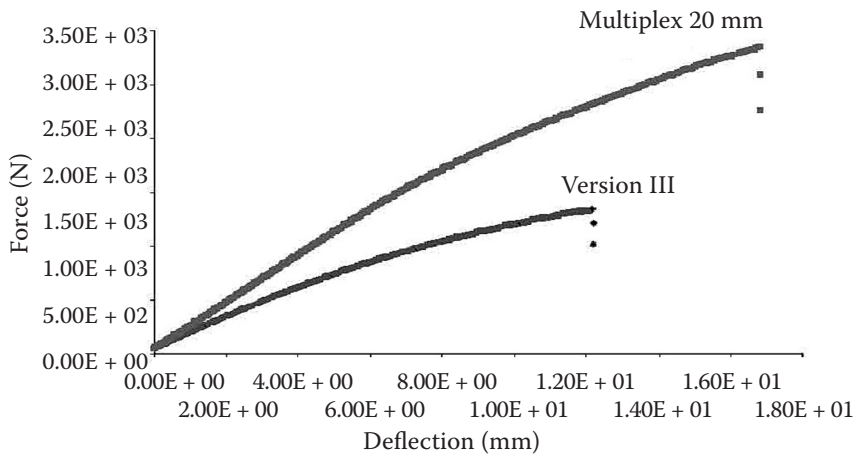

Fig. 9. Comparison of the course of force and deflection – bending strength across the grain – Variant 3

Basic descriptive statistics were computed: arithmetic mean  $m$ , standard deviation  $s$ , coefficient of variation  $V$ , lower fractile of normal distribution  $L_{5\%}$ . Tables 1 to 7 show the results of tests of physical and mechanical properties of the following combined plywoods:

- Variant 1 – Plywood with fibreglass (11-ply, thickness 16 mm)
- Variant 2 – Plywood with a cork core (11-ply, thickness 22 mm)
- Variant 3 – Plywood with a cork core and a cork wear layer (12-ply, thickness 25 mm).

And for the purpose of comparison:

- Multiplex 20 mm thick
- Multiplex 15 mm thick.

At this test, the rupture of a cork layer occurred in all test specimens without the exposure of a glue line.

Figs. 6 to 9 illustrate the course of force and deflection at the determination of bending strength along the grain and across the grain in Variants 1 and 3. Fig. 12 illustrates the course of tension in separate layers in pressure and tensile in bending: (a) along the grain of outer veneers, (b) across the grain of outer veneers.

## DISCUSSION

Combined plywoods with fibreglass (Variant 1) are intended exclusively for floors of lorries and other vehicles, for constructions of platforms, industrial floors etc. From the aspect of the indicated use bending strength and modulus of elasticity in bending are important properties. On the basis of tests of the properties and comparing properties of Multiplex boards it is possible to conclude that all materials under examination have nearly the same bending strength (Tables 1 to 4).

No significant effects of fibreglass on bending strength and modulus of elasticity in bending (MOE) were proved. However, it is possible to suppose the

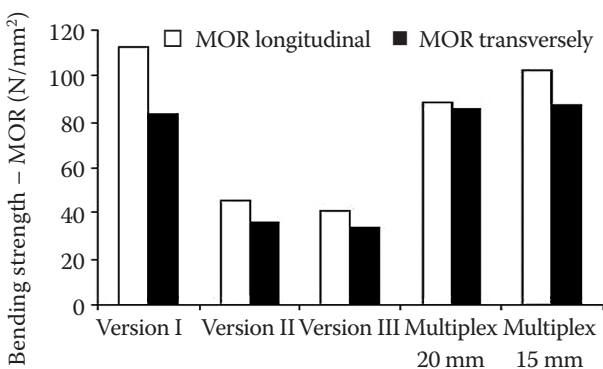

Fig. 10. Comparison of the bending strength of combined plywoods, Variants 1–3



Table 3. Bending strength  $f_m$  and modulus of elasticity  $E_m$  across the grain ( $N/mm^2$ ) – ČSN EN 310

Property	Variant 1		Variant 2		Variant 3	
	$f_m$	$E_m$	$f_m$	$E_m$	$f_m$	$E_m$
$m$	83.82	7,955.75	35.95	5,386.83	33.58	2,263.17
$s$	3.27	346.36	7.68	530.16	4.33	258.89
$L_{5\%}$	77.93	7,332.30	22.12	4,432.55	25.79	1,797.17
$V$ (%)	3.90	4.35	21.37	9.84	12.89	11.44

Table 4. Bending strength  $f_m$  and modulus of elasticity  $E_m$  across the grain ( $N/mm^2$ ) – ČSN EN 310

Property	Multiplex 20 mm thick		Multiplex 15 mm thick	
	$f_m$	$E_m$	$f_m$	$E_m$
$m$	85.67	8,121.13	87.52	8,719.60
$s$	6.92	403.60	16.39	1,239.43
$L_{5\%}$	72.59	7,358.32	57.53	6,451.44
$V$ (%)	0.24	4.97	0.75	14.21

Table 5. Density of combined plywoods ( $kg/m^3$ ) – ČSN EN 323

Property	Variant 1	Variant 2 density $\rho$	Variant 3
$m$	815.88	592.12	565.74
$s$	10.97	9.61	9.80
$L_{5\%}$	795.14	573.96	547.22
$V$ (%)	1.34	1.62	1.73

Table 6. Moisture of combined plywoods (%) – ČSN EN 322

Property	Variant 1	Variant 2 moisture H	Variant 3
$m$	5.04	5.24	5.79
$s$	1.21	0.98	0.14
$L_{5\%}$	2.74	3.38	5.51
$V$ (%)	24.09	18.76	2.49

Table 7. Shearing strength test of a cork layer ( $N/mm^2$ ) – ČSN EN 314-2

Property	Variant 2
	$\tau$
$m$	0.49
$s$	0.04
$L_{5\%}$	0.43
$V$ (%)	7.26

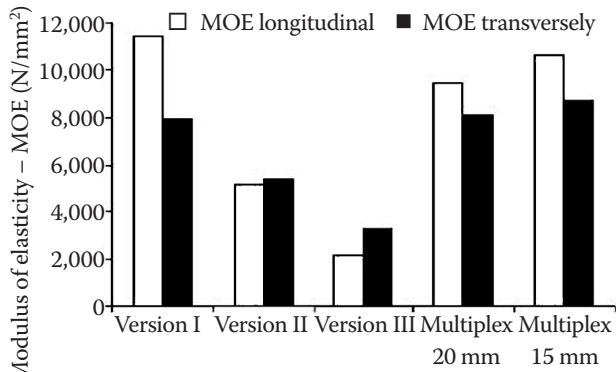

Fig. 11. Comparison of the modulus of elasticity in bending of combined plywoods, Variants 1–3

effects of fibreglass on abrasive resistance and decreased combustibility of combined plywood materials. Determination of these parameters will be the subject of further research.

It is supposed that combined plywoods with a cork core (Variant 2) will be used in the construction of rail and road vehicles where the sound insulation of inner spaces (interior) is important. The bending strength of these boards as compared with Multi-

plex boards 20 mm thick is markedly lower (Tables 1–4 and Figs. 10–11). The value of the bending strength of plywoods with a cork core along the grain ( $46.07 N/mm^2$ ) and across the grain ( $35.95 N/mm^2$ ) is sufficient for intended purposes. This value can be, however, increased using beech veneers instead of spruce veneers in the whole construction of plywoods. The density of plywoods significantly affects the capacity of the material to dampen noise. To achieve good sound-proof properties materials of a density of  $630 kg/m^3$  are ordinarily used (e.g. Polyvan 31, sound attenuation 33 dB). Therefore, it is suitable to think about increased density roughly to this value even in combined plywoods with a cork core.

It is also possible to replace spruce veneers by beech veneers in the whole construction. Determination of sound-proof properties will be the subject of next research. The quality of gluing was satisfactory, the disturbance of test specimens occurred always in the layer of cork because its shearing strength was low.

Combined plywoods with a cork wear layer (Variant 3) show a similar purpose of use as the

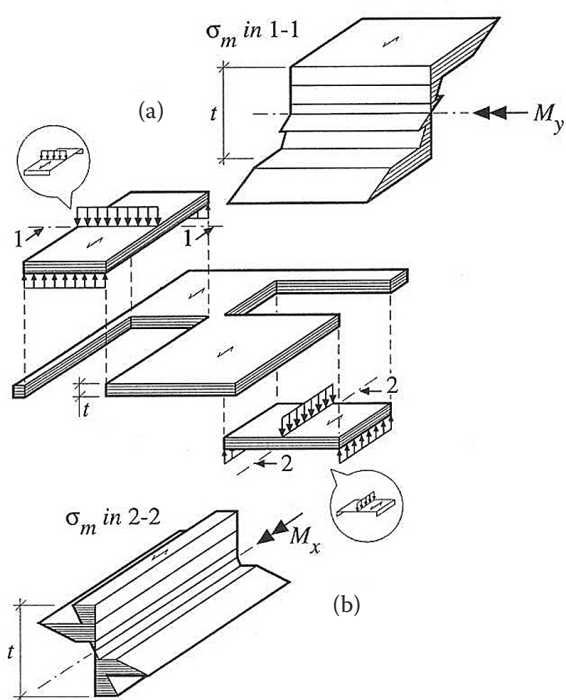

Fig. 12. Diagram of the course of tension in separate layers in pressure and tensile in bending (a) along the grain of outer veneers, (b) across the grain of outer veneers

previous type. They can be used for floor elements with a cork wear layer. However, this layer has to be surface-finished. Changes in properties in this type of material compared to combined plywood with a cork core can be observed only in density, which is logical. The volume of the plywood increased (thickness), however, the weight increased only slightly because cork is very light. Surface density, however, increased from 13.02 kg/m<sup>2</sup> to 14.41 kg/m<sup>2</sup>.

## CONCLUSION

The aim of the paper was to determine properties of newly developed plywood materials combined with cork and fibreglass and to compare them with common plywoods, viz. multiplexes. These newly developed plywood materials were also compared with similar materials produced by renowned companies. Under pilot plant conditions, three variants of combined plywood materials were pressed, namely with a layer of fibreglass, with a cork core layer and with a cork wear layer on one side of the plywood board and a cork core. Tests of selected physical and mechanical properties were carried out on these materials including basic statistical evaluation. A comparison with plywood materials Multiplex 15 and 20 mm thick was also made. As for

the pressed variants of combined plywood materials (I–III) only plywoods combined with fibreglass (Variant I) reach the required values of mechanical properties of Multiplex boards 15 and 20 mm thick. Plywoods with a cork layer (Variants II and III) show lower strength properties.

Within this research, the following parameters were not examined:

- the surface resistance with the Taber apparatus in plywoods with fibreglass;
- the surface resistance by a rolling test which simulates the passage of a cart for plywoods with fibreglass;
- noise attenuation in both types of plywoods with cork;
- attenuation of footfall sound in plywood with a cork surface layer.

The refraction of materials in the whole profile and also in separate layers was not examined. The failure of materials at separate layer interface owing to shear in bending oneself partially approved. This is again a theme of another research inclusive of determination of the elastic constant according to separate layers.

Appropriate tests to determine parameters mentioned above will be the subject of follow-up research.

## References

- BAO Z., ECKELMAN C., GIBSON H., 1996. Fatigue strength and allowable design stresses for some wood composites used in furniture. *Holz als Roh und Werkstoff*, 54: 377–382.
- HRÁZSKÝ J., KRÁL P., 2004. Analysis of properties of boards for concrete formwork. *Journal of Forest Science*, 50: 382–398.
- HRÁZSKÝ J., KRÁL P., 2005. Effects of the thickness of rotary-cut veneers on properties of plywood sheets. Part 1. Compressibility of plywood materials. *Journal of Forest Science*, 51: 313–321.
- KRÁL P., HRÁZSKÝ J., 2003. Effect of negative factors on the use of oak and beech. *Journal of Forest Science*, 49: 281–289.
- KRÁL P., HRÁZSKÝ J., 2006. Effects of different pressing conditions on properties of spruce plywoods. *Journal of Forest Science*, 52: 285–292.
- SHARP D.J., SUDDARTH S.K., 1991. Volumetric effects in structural composite lumber. In: *Proceedings, 1991 International Timber Engineering Conference, 1991 September 2–5, London*, 3: 427–437.

Received for publication June 6, 2007

Accepted after corrections July 11, 2007

## Příspěvek k vlastnostem kombinovaných překližovaných materiálů

**ABSTRAKT:** V článku jsou shrnuty výsledky institucionálního výzkumu zaměřeného na nové typy kombinovaných překližovaných materiálů. V poloprovozních podmínkách byly odlisovány tři varianty kombinovaných překližovaných materiálů, a to s vrstvou skelného vlákna, s jádrovou korkovou vrstvou a s korkovou nášlapnou vrstvou na jedné straně povrchu překližované desky a korkovým jádrem. Na těchto materiálech byly provedeny zkoušky vybraných fyzikálních a mechanických vlastností včetně základního statistického vyhodnocení. Bylo rovněž provedeno srovnání s překližovanými materiály Multiplex o tloušťce 15 a 20 mm.

**Klíčová slova:** kombinovaná překližka; hustota; vlhkost; pevnost v ohybu; modul pružnosti v ohybu; statistická analýza; korkové jádro; povrch se skelným vláknem

---

*Corresponding author:*

Doc. Dr. Ing. JAROSLAV HRÁZSKÝ, Mendelova zemědělská a lesnická univerzita v Brně, Lesnická a dřevařská fakulta,  
Lesnická 37, 613 00 Brno, Česká republika  
tel.: + 420 545 134 159, fax: + 420 545 134 157, e-mail: hrazsky@mendelu.cz

---