

Research on individual parameters for cutting power of woodcutting process by circular saws

J. KOVÁČ, M. MIKLEŠ

Department of Forest and Mobile Technology, Faculty of Environmental and Manufacturing Technology, Technical University in Zvolen, Zvolen, Slovakia

ABSTRACT: Nowadays, the wood cutting process looks like a technological scheme consisting of several connected and relatively inseparable parts. Wood crosscutting is the most widespread operation in the process of forest exploitation; it is used at tree exploitation, shortening stems and assortment production. The article deals with the influence of the cutting edge geometry of circular saws on the torque and also on the cutting performance at wood crosscutting, therefore there is an influence on the whole cutting process. In the present article measurement procedure, used measuring devices and the process of result analysis are described in detailed. Knowledge of the wood crosscutting process and choice of suitable cutting conditions and cutting tools will contribute to a reduction in production costs and to energy saving.

Keywords: circular saw; cutting edge geometry; cutting power; wood crosscutting

The nature of the cutting process for all ways of mechanical wood machining can be understood more easily when the elementary factors are known. Wood crosscutting is the most widespread operation in the process of forest exploitation; it is used at tree exploitation, shortening stems and assortment production. Longitudinal cutting is mainly applied in subsidiary enterprises (sawmills) and basic wood industry. Mixed cutting is used in furniture production. At the forest exploitation there comes to its application at the executing the cut on trees underlying harvesting trees by circular saws. Nowadays, the wood cutting process is considered as a technological scheme. It consists of several connected and relatively inseparable parts (MARKO, HOLÍK 2000). The technological system called “cutting process” consists of four parts – subsystems: a workpiece (species of wood, humidity, density, toughness, elasticity, temperature, dimensions, etc.), cutting conditions (they represent the sum of conditions relating to workpiece, cutting tool and cutting mechanism which are necessary for initialization of the cutting process), a cutting mechanism (it is a mechanism of main movement,

feed, number of working movements and procedure of their performance, thickness and width of a layer which is cut, cutting angle, speed of cutting movement and feed, cutting forces and friction forces, performance of motors, etc.) and a cutting tool (cutting-wedge angle, number of teeth, material properties, surface roughness, cutting edge length, etc.).

Crosscutting wood by circular saws

The penetrating tooth of a circular saw into wood causes the reciprocal action of forces between the wood and cutting edge (Fig. 1). The cutting wedge presses on resisting wood. The result is the load of the frontal, rounded and back surface of a cutting wedge. The cutting resistance is a resistance which is created at the chip separated by a wedge. The cutting resistance is a reaction to the cutting force, it has the same size but opposite direction (LISIČAN 1996).

All resistances that act on the cutting wedge of the circular saw tooth have the resultant force F which is called cutting resistance. It consists of the following parts:

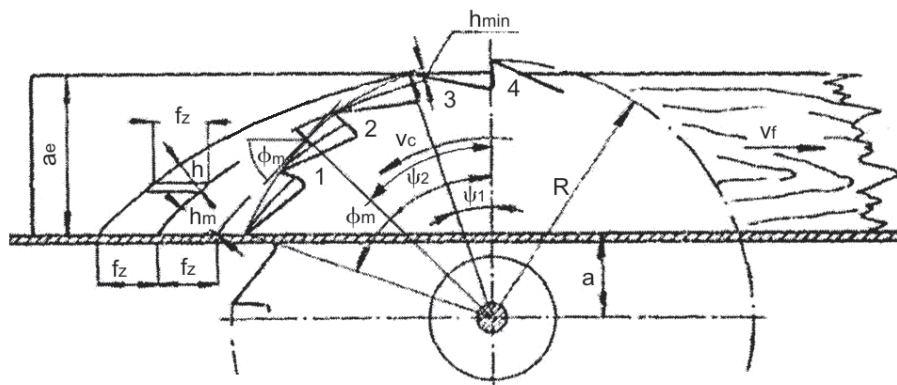

Fig. 1. The scheme of circular saw cutting

where: f_z – feed per one tooth (m), a_e – cutting height (m), v_f – feed rate ($\text{m}\cdot\text{s}^{-1}$), v_c – cutting speed ($\text{m}\cdot\text{s}^{-1}$), ψ_1 – the entry angle of circular saw ($^\circ$), ψ_2 – the exit angle of circular saw ($^\circ$), Φ_m – mean angle of cut fibres ($^\circ$), h_m – max. thickness of a chip (mm)

- forces necessary for cutting the mass of a workpiece by a cutting-wedge during the deformation of a mass in the surroundings of a cutting edge,
- forces necessary for deflection of chips and suppression of chip friction against the leading edge of the tooth,
- forces necessary for suppression of friction on the back and leading surfaces against the machined surface.

Defining the value of individual parts of force F is quite difficult and depends on many aspects. The part of force F in the direction of cutting feed F_c is called cutting force and it is used for practical calculations of energetic relations during the cutting process. The part perpendicular to force F_c represents the pressure of the circular saw tooth on the surface of a machined surface and it is called withdrawal force F_w . If its value is positive (going down), the material is pressed onto the table. If its value is negative (going up), this force lifts up the material and it is necessary to provide the stability of the material by a pressing mechanism (HOLOPÍREK, ROUSEK 2004).

Cutting force F_c acting on the tooth of a circular saw takes chips at the width b and thickness h . The cutting force value is then given by the multiplication of cutting resistance for disintegrated material K and the surface of chip crosscutting.

$$F_c = K \times b \times h \quad (\text{N}) \quad (1)$$

The dimension of cutting work A_c on condition that the cutting resistance is constant in all phases of the cutting process can be defined as follows:

$$A_c = F_c \times l = K \times b \times h \times l \quad (\text{J}) \quad (2)$$

where:

l – cutting way of a tooth in the material (mm)

The cutting power is defined as the multiplication of cutting force F_c and cutting speed v_c :

$$P_c = F_c \times v_c \quad (\text{W}) \quad (3)$$

Another way of cutting power definition is the amount of work released per one second. The unit of power is W ($W = \text{N}\cdot\text{m}\cdot\text{s}^{-1}$).

$$P_c = \frac{A_c}{t} \quad (\text{W}) \quad (4)$$

We can calculate the cutting power also by means of the torque according to:

$$P_c = \frac{2 \times M_k \times v_c}{D} \quad (\text{W}) \quad (5)$$

where:

M_k – torque (N·m),

D – diameter of a circular saw (m).

Cutting conditions in the process of woodcutting by circular saws

According to the shape of a circular saw in the crosswise cut we can recognize the following circular saws: flat, relieved (called planning), concurrent (on the left or on the right side or reciprocal) and saddle (on the left or right side). The concurrent or saddle parts of circular saws are defined in the course of a workpiece feed against the teeth. According to the cutting course regarding the arrangement of wood fibres circular saws for crosswise and longitudinal cutting are used (MIKLEŠ, MARKO 1992). They differ in the tooth profile and in the way of sharpening. The tooth profile and the way of sharpening must correspond to the required performance of a circular saw and to the quality of machined surface. They must be released according to the type of workpiece (soft, hard wood and other types of workpieces) and the material of cutting edge (tool steel, cemented carbide plates).

Maximum revolutions at the maximum speed $100 \text{ m}\cdot\text{s}^{-1}$ are set forth in each circular saw. This

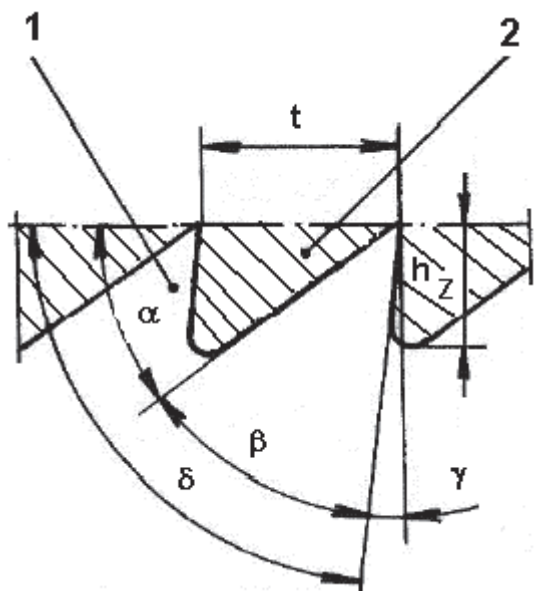

Fig. 2. The scheme of cutting tool geometry (i.e. circular saw geometry)

1 – tooth, 2 – tooth gap, t – spacing of teeth, h_z – spacing height, α – cutting clearance angle, β – cutting-wedge angle, γ – cutting-edge side rake, δ – cutting angle

speed is not a working speed but it shows operational reliability which is guaranteed by the manufacturer. For getting the optimal performance of a circular saw it is necessary to choose cutting conditions according to the cut material. The recommended cutting speeds of a circular saw according to the material are:

- soft wood $60\text{--}100\text{ m}\cdot\text{s}^{-1}$,
- hard and exotic wood $50\text{--}85\text{ m}\cdot\text{s}^{-1}$.

In the range of recommended cutting speeds for chosen material there are oriented regarding the requirements for the cutting surface quality, technological state of a machine etc. Continuing the recommended cutting speeds does not have any practical

meaning and it is not recommended for economical reasons. Circular saws have a robust construction and they are most frequently used in crosscutting lines when handling thin and medium stems (up to 40–50 cm). Their advantages are high cutting ability, maintainability and long lifetime.

In practice it is very important to continue the whole cutting process with the lowest power consumption. More factors influence the power consumption, e.g. the choice of a suitable material for the cutting tool, its geometry and optimal cutting conditions (cutting speed v_c , feed rate v_f , feed per one tooth f_z). The cutting power is very important and it is the factor of power consumption. Along with other cutting conditions the cutting angle is decisive for the performance of tools, machines, economics of all machining types, machined surface quality and dimensional exactness of a workpiece. Cutting angles of a circular saw are shown in Fig. 2. The wrong cutting angles can diminish the machined surface quality, accelerate dulling and decrease the lifetime of a tool, increase the cutting resistance and influence the lifetime of a machine and efficiency of the operation (LISIČAN, ZEMIAROVÁ 1988).

The cutting-wedge angle β . When the cutting-wedge angle is larger (i.e. the angle of the cutting part of a tool), the cutting resistance of the material is also higher. It is better when the cutting angle is as small as possible but when the cutting angle is smaller than a certain value, the hardness of the cutting edge is very low and it becomes weaker and blunts very fast. When we want to define the cutting-wedge angle, we have to define the values of angles α and γ . This angle is the same in cemented carbide plates and in high-speed steel, because cemented carbide plates are fragile.

The cutting clearance angle α . Mainly friction between the cutting clearance angle and processed surface influences the cutting clearance angle. When this angle is smaller, the friction is higher and *vice*

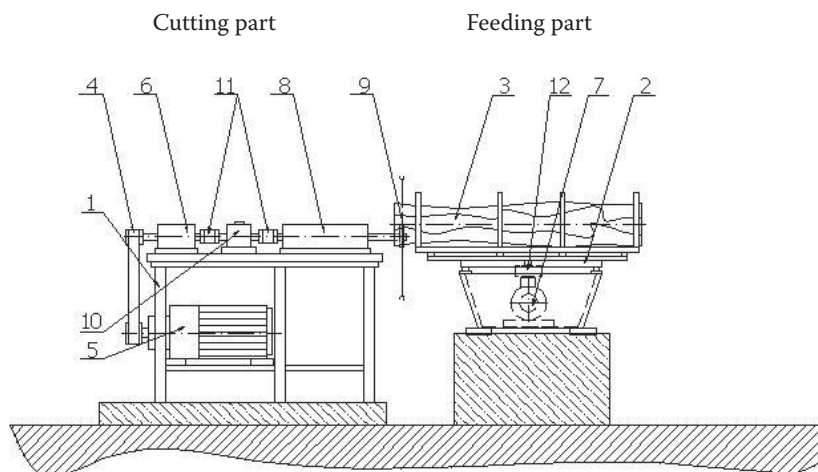

Fig. 3. The scheme of an experimental measuring device

1 – working table, 2 – sliding line, 3 – round timber, 4 – gear of belts for the driving of a circular saw, 5 – electric motor for the driving of a circular saw, 6 – bearing cover, 7 – electric motor for the driving of the material to the cut, 8 – spindle head of a circular saw, 9 – circular saw, 10 – T20WN recorder of torques and revolutions, 11 – GFL-28 clutch, 12 – S2 force recorder

Table 1. Basic parameters of circular saws

Basic dimensions	Saw diameter D (mm)	Saw width B (mm)	Cutting-clearance angle α (°)	Cutting-edge side rake (°)	No. of teeth
Circular saw made of high-speed steel	600	5.4	20	-5, 0, 5, 10	56
Circular saw with cemented carbide plates	600	5.4	15	-10, 0, 10, 20	54

versa. It is the effect caused by decreasing cutting clearance angle and surface between the cutting clearance and processed surface directly behind the cutting edge. This surface gets gradually increased with higher blunting of the cutting edge because the round surface of blunt cutting edge does not cut the material in the process of chip cutting. It is mainly in the plain passing the lowest point of the cutting edge but it is also in the plain lying a little bit higher. The cutting clearance angle has a direct influence on the dimension of cutting resistance and the whole work of cutting. In practice the cutting clearance angle is between 10° and 30°.

The cutting-edge side rake γ . The cutting-edge side rake influences the chip process creation and the size of a chip. It has an important meaning in industrial chip processing, e.g. in the production of chipboards. The optimal value depends also on the type of processed material, direction of fibres and dimension of feed on edge or possibly on the thickness of a chip.

MATERIAL AND METHODS

The experimental measuring device was developed for research on wood crosscutting parameters and on cutting tools. Its scheme is shown in Fig. 3. The measuring equipment consists of two parts, i.e. cutting and feeding parts. The cutting part provides development and transfers the torque to a tool. The feeding part provides workpiece clamping and feeding wood into the cut.

As it is shown in the scheme, a three-phase asynchronous 7.5 kW electric motor is used. Its torque is transmitted by the spindle head to a tool (circular saw). The wood sample is fixed on the plate in the holder by a lever system which provides safety holding. The crosswise feeding of the workpiece is provided by a 5.5 kW electric motor by means of a safety clutch and a feed screw. An HBM S2 force sensor is placed between the nut and the plate. Cables transmit measured signals of the force and torque

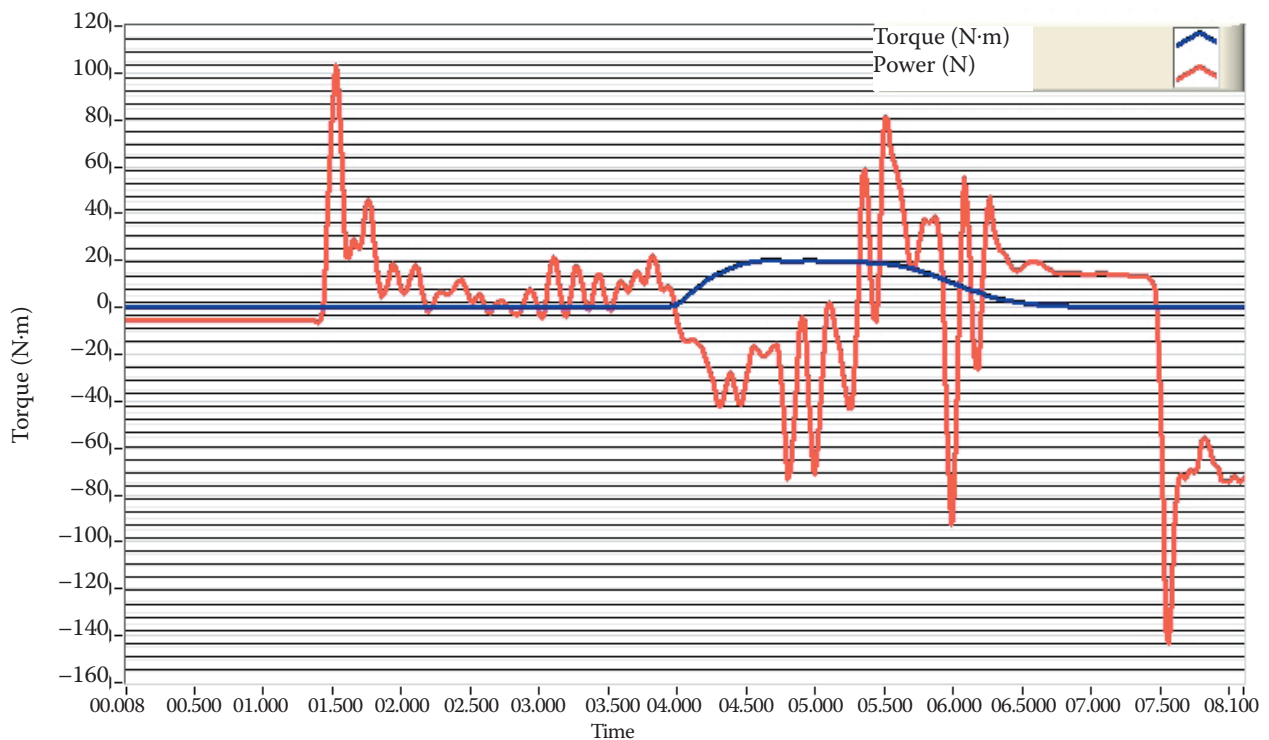

Fig. 4. The course of M_k and compressive force to the cutting in wood (beech) crosscutting

Table 2. Arithmetic means of maximal values of P_c for the particular values of cutting-edge side rake on circular saws

Species of wood/ cutting-edge side rake (°)	Value of cutting power P_c (kW)							
	circular saw made of high-speed steel				circular saw with cemented carbide plates			
	10	5	0	-5	20	10	0	-10
Beech	3.5875	3.8342	4.0389	4.0947	3.9813	3.8919	3.9554	4.0011
Oak	3.7427	3.8898	4.1126	4.1305	4.0648	3.7805	3.9057	4.0131
Spruce	3.8063	3.9833	4.1245	4.1046	4.2219	3.9077	3.9833	4.1921

to a SPIDER-8 measuring centre which is connected to a PC. The torque sensor HBM T20WN enables to register the revolutions of a circular saw. Frequency converters with vector control regulate the revolutions and the power of electric motors.

In experimental tests wood samples 18 cm in diameter and 1.5 m in length were used. The wood samples were made of beech, oak and spruce. Their moisture was approximately 45% in spruce, 50–60% in beech and oak. It was measured by the weighing method. The samples were cut by circular saws with cemented carbide plates and made of high-speed steel (their technical parameters are shown in Table 1).

The measurement of wood (beech and oak) was done at circular saw revolutions $1,900 \text{ rev}\cdot\text{min}^{-1}$, at the cutting speed $59.66 \text{ m}\cdot\text{s}^{-1}$ and feed rate $152 \text{ m}\cdot\text{s}^{-1}$. The feed rate in spruce wood was decreased because of the circular saw jamming in the wood-cutting process. It was $103 \text{ mm}\cdot\text{s}^{-1}$.

RESULTS AND DISCUSSION

A partial purpose of the experiment was to determine the influence of different cutting-edge side rakes on the torque value and compressive force to the cut (Fig. 4). The cutting-edge side rake influenced

cutting resistance and the whole process of wood crosscutting. The results were processed by the Conmes Spider program.

From the torque M_k course at cutting of beech by a circular saw with cemented carbide plates it was possible to see a great increase in its value at the beginning of the penetration of a tool (circular saw) into the cut, then there was a certain decrease in this value, which was caused by the inertia of a circular saw, and then following fixation of the cutting process. Then the cutting process ran at a certain constant value (the torque value changed very little), only at the end of the cutting process the value reached the state when the circular saw rotated without any load. The course of torque M_k in the cutting process of circular saws made of high-speed steel was characterized by a high increase to the maximal value, then it decreased a little to a certain value and finally it decreased rapidly, which was caused by cutting out the wood.

From the obtained results of the torque M_k at different cutting-edge side rakes of circular saws with cemented carbide plates and circular saws made of high-speed steel in different types of wood we deduced the maximal values of M_k in the particular measurements and we carried out the analysis of basic statistical results (Table 2).

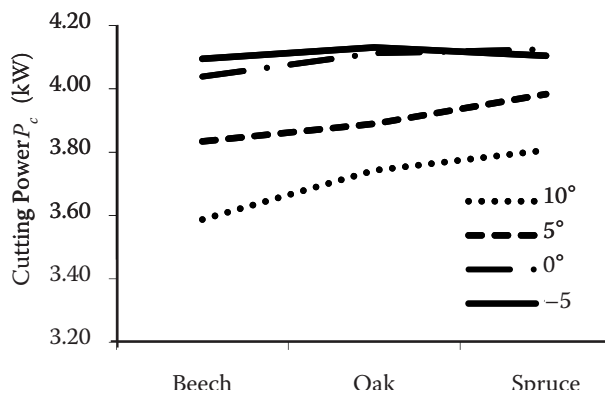

Fig. 5. The value of cutting performance P_c in the process of wood crosscutting by a circular saw made of high-speed steel

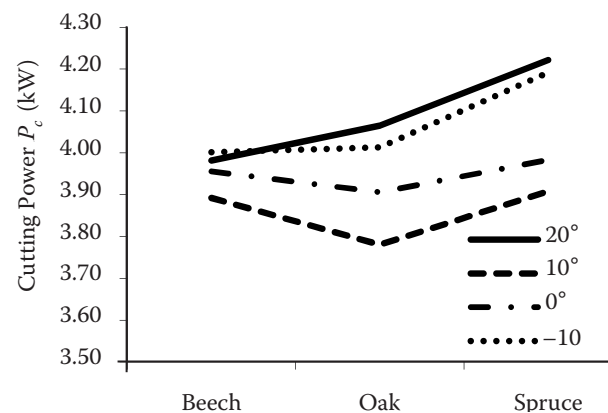

Fig. 6. The value of cutting performance P_c in the process of wood crosscutting by a circular saw with cemented carbide plates

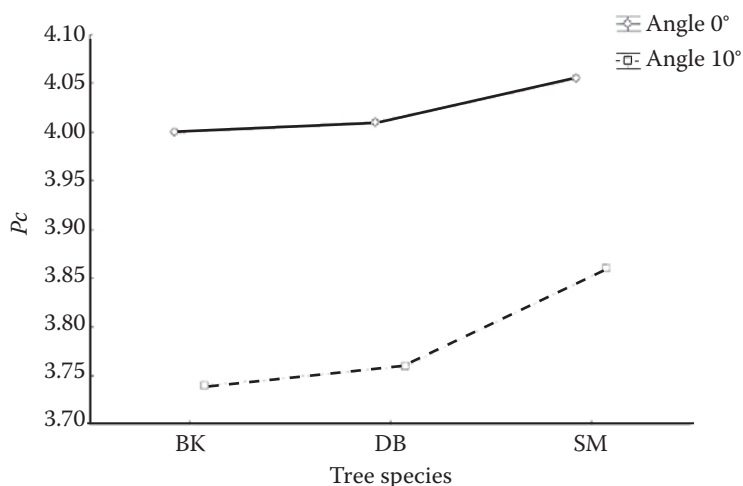

Fig. 7. Influence of the cutting-edge side rake of a circular saw on the cutting power according to the type of wood species

Then we created the graphical evaluation of arithmetic means of maximum values M_k , which gives a better overview of obtained results. The value of cutting power is calculated from the torque due to the diameter of a circular saw $D = 600$ mm and the cutting speed

$$v = 59.66 \text{ m}\cdot\text{s}^{-1}.$$

To determine reciprocal dependences of more parameters regarding the power consumption of the woodcutting process by circular saws (torque and maximum power were chosen as criteria) multifactorial analysis of variance ANOVA was used. We wanted to find out reciprocal statistical dependences between maximum power (as dependent variable), wood type, type of circular saw and the cutting-edge side rake (as independent variable). There is an assumption that these parameters can influence each other. For each physical parameter the results were

statistically evaluated by three-factor analysis of variance. We decided to consider only two values of cutting-edge side rake, i.e. 0° and 10° , as important. The reason was that negative values of the cutting-edge side rake of a circular saw were the values that were the most unfavourable. Graphical and statistical evaluations are shown in Figs. 4–6.

From the input factors of the cutting process (wood type, cutting-edge side rake, type of a circular saw) it is possible to definitely generalize as follows:

- wood type is an important factor influencing power consumption in the cutting process and cutting power,
- the cutting-edge side rake of a circular saw is another important factor influencing cutting power P_c ,
- of all those factors the change of circular saw type (with the same geometry) has the highest influence on cutting power.

The evaluation of the above-mentioned statistical results of measurements for the values of cutting

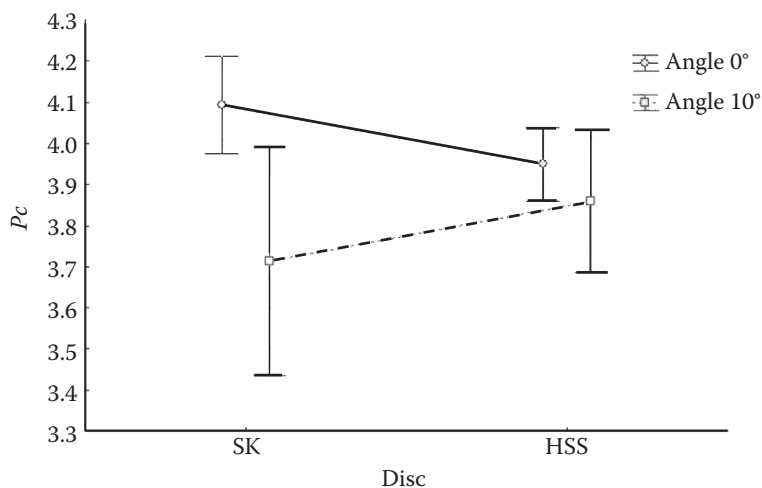

Fig. 8. Influence of the cutting-edge side rake of a circular saw on the cutting power according to the type of circular saw

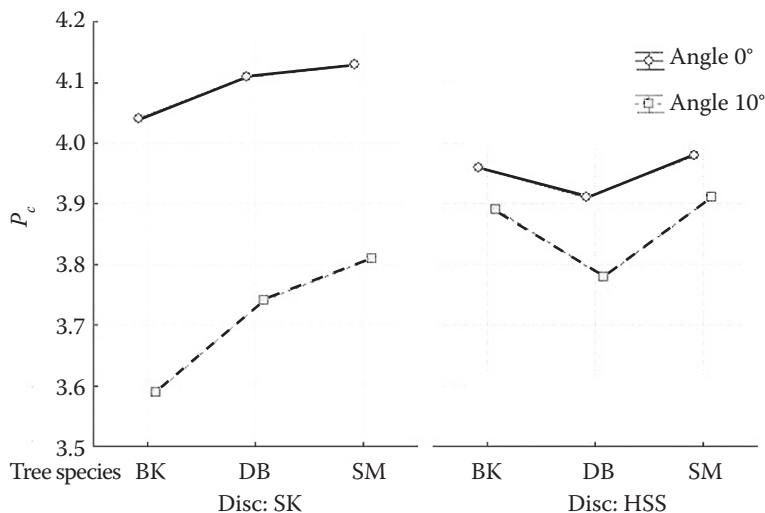

Fig. 9. Final interaction of the cutting-edge side rake of a circular saw, wood species and type of circular saw in relation to the cutting power

power P_c at individual cutting-edge side rakes of circular saws, wood type and type of circular saw confirmed that the best value of the cutting-edge side rake at wood crosscutting by circular saws with cemented carbide plates and circular saws made of high-speed steel, where the positive value for cutting-edge side rake (10°) is also at wood type what the confirmation of recent results in the theory of crosswise wood cutting is.

CONCLUSION

In practice it is very important that the whole process of wood crosscutting should run with the lowest power consumption. There are many factors which influence its power consumption, e.g. material of the cutting tool, its geometry and optimal cutting forces (cutting speed v_c , feed rate v_f). The cutting power is a very important factor of power consumption. The utilization of circular saws with unsuitable technical and technological parameters in the given conditions of work can be expressed by following deficiencies: fast circular saw wearing and bad quality of the cut, higher power consumption, higher wood consump-

tion in the process of production because big additions for machining are necessary.

References

- HOLOPÍREK J., ROUSEK M. (2004): Comparison of the theoretical calculation of resistance in cutting particleboards with an experiment. In: Chip and Chipless Wood-cutting '04. Book of Presentations IV. Chip and Chipless Wood-cutting. Starý Smokovec, 14.–16. October 2004. Zvolen, Technická univerzita vo Zvolene: 99–104. (in Czech)
- LISIČAN J. (1996): Theory and Technique of Wood Processing. Zvolen, Matcentrum: 626. (in Slovak)
- LISIČAN J., ZEMIAROVÁ B. (1988): Processing and Cutting of Wood Materials. Materials for practice. Zvolen, Technická univerzita vo Zvolene. (in Slovak)
- MARKO J., HOLÍK J. (2000): Theory of Wood Cutting. Zvolen, Technická univerzita vo Zvolene. (in Slovak)
- MIKLEŠ M., MARKO J. (1992): Theory and Construction of Forest Machines I. Zvolen, Technická univerzita vo Zvolene. (in Slovak)

Received for publication September 23, 2009
Accepted after corrections November 9, 2009

Corresponding author:

Ing. JÁN KOVÁČ, Ph.D., Technická univerzita vo Zvolene, Fakulta environmentálnej a výrobnjej techniky, Katedra lesnej a mobilnej techniky, T. G. Masaryka 24, 960 53 Zvolen, Slovensko
tel.: + 421 455 206 517, fax: + 421 045 532 0015, e-mail: kovac@vsld.tuzvo.sk